

# ***SLOPE-TACH*** ADAPTER

## **INSTALLATION & PARTS MANUAL MODEL ST2**

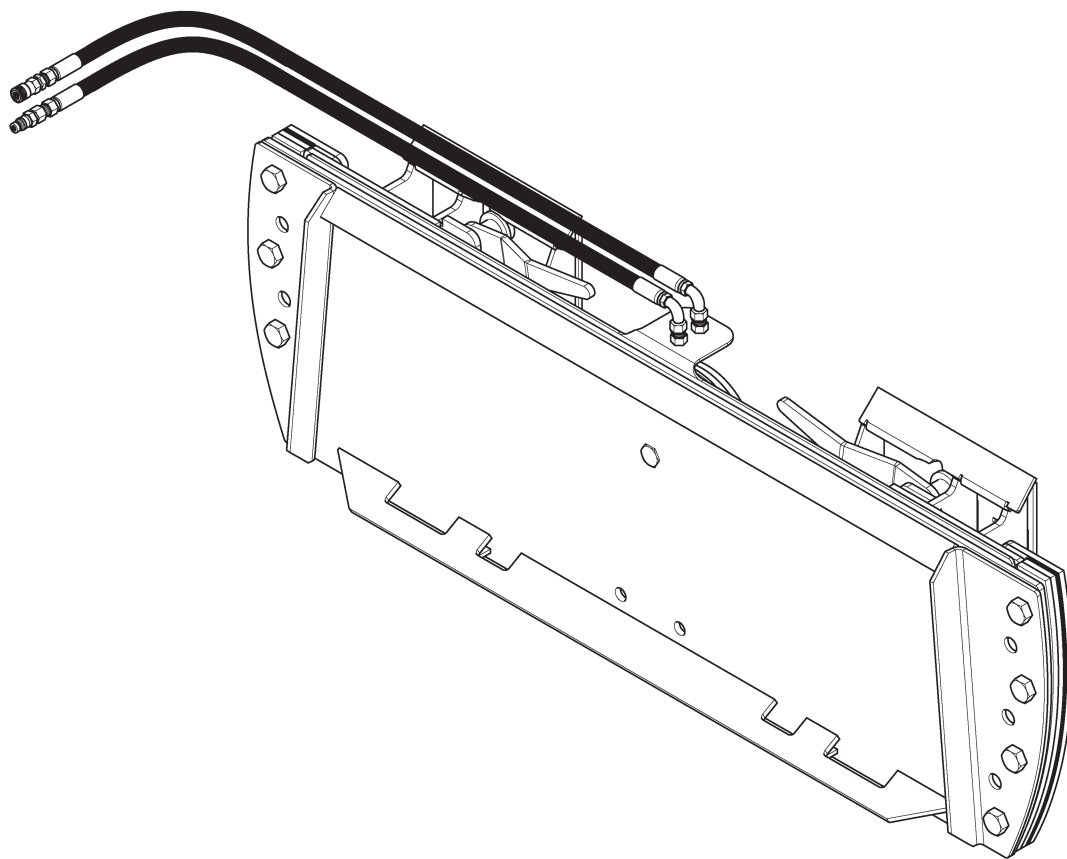

**ATI**   
CORPORATION

New Holland, PA 17557

Phone (717) 354-8721 • FAX (717) 354-2162

1-800-342-0905

[www.preseeder.com](http://www.preseeder.com)

**OCTOBER 2008**

CAT.# SlopeTachII-IPM-1008





New Holland, PA 17557  
Phone (717) 3564-8721 • FAX (717) 354-2162  
**1-800-342-0905**  
[www.preseeder.com](http://www.preseeder.com)

**COPYRIGHT 2008 by  
ATI Corporation  
New Holland, PA 17557 U.S.A.**

## **DISCLAIMER**

THE INFORMATION IN THIS MANUAL IS PROVIDED TO PROMOTE THE SAFE USE OF, AND ASSIST THE OPERATOR IN ACHIEVING THE BEST PERFORMANCE FROM, THE PRODUCTS DESCRIBED HEREIN WHEN USED FOR THE INTENDED APPLICATION.



New Holland, PA 17557  
Phone (717) 3564-8721 • FAX (717) 354-2162  
**1-800-342-0905**  
[www.preseeder.com](http://www.preseeder.com)

## Slope-Tach Adapter

### Standard Models

<b>Kit Part Number</b>	<b>Description</b>	<b>Fits Model Numbers</b>
100-182-000	Slope-Tach General	PL72, PL84, PL96
100-183-000	Slope-Tach for Buckets	

# Slope-Tach Adapter

## Table of Contents



New Holland, PA 17557  
Phone (717) 3564-8721 • FAX (717) 354-2162  
**1-800-342-0905**  
[www.preseeder.com](http://www.preseeder.com)

Standard Models .....	ii
Table of Contents .....	iii
Serial Number Information .....	iv
Where to Get Parts and Service .....	iv
How To Order Parts .....	v
List Of Parts Illustrations .....	vi
Safety, Installation, Operation & Maintenance .....	1
Safety .....	1
Overview .....	1
Installation .....	1
Mounting the Slope-Tach on the Skid Steer Loader .....	1
Skid Steer Loader Hydraulic Connections .....	2
Installing Attachments on the Slope-Tach Adapter .....	3
Maintenance .....	3



New Holland, PA 17557  
 Phone (717) 3564-8721 • FAX (717) 354-2162  
**1-800-342-0905**  
 www.preseeder.com

# Slope-Tach Adapter

## SERIAL NUMBER INFORMATION

It is very important that the correct serial number is provided when ordering parts. The serial number plate is located on the main frame. Please mark the model and serial number of your Slope-Tach adapter in the space provided below in case the plate on the Slope-Tach adapter is lost or damaged.

**Model .....**Serial Number .....

**Dealer Name .....**Dealer Phone Number .....

## WHERE TO GET PARTS AND SERVICE

When replacement parts and service are required, ATI Corporation recommends returning to the dealer from which the product or optional kit was purchased. By going to the dealer, you are dealing with people that understand and know ATI products. Our dealers have the experience servicing these machines and stock the most common parts required to keep your equipment in top working condition.

*NOTE:*

**ATI Corporation reserves the right to discontinue models at any time, change specifications, and improve design without notice and without incurring obligation on goods previously purchased and to discontinue supplying any part listed when the demand does not warrant production.**

# Slope-Tach Adapter



New Holland, PA 17557  
Phone (717) 3564-8721 • FAX (717) 354-2162  
**1-800-342-0905**  
[www.preseeder.com](http://www.preseeder.com)

## HOW TO ORDER PARTS

Parts lists contained in this book have been prepared to help you when ordering spare and/or replacement parts. Your order will be filled promptly and accurately when the following information is provided:

1. Model and serial number of the unit. (This specifically identifies the equipment you have and permits us to verify the part numbers in your order.)
2. The parts list page number and catalog number. Include catalog revision number, if applicable.
3. The **Item** number for each part. **Item** numbers on the parts list page correspond with the numbers shown on the illustration.
4. **Part Number** as it appears in the parts list. In most cases this will be a nine-digit number; for example: 200-147-000.
5. The **Description** for the part as it appears on the parts list page.

The part ordered may have a new part number, or the part may have been replaced by a newer design with a different part number. In these cases your acknowledgement, shipping papers and invoices will be written listing the current part number first; the old part number you referred to will follow the part description.

Our purpose in doing this is to tell you that the parts are fully interchangeable. This will avoid any unnecessary correspondence or delay in processing your order. We suggest that you add any new number to your parts lists for future use.



New Holland, PA 17557  
Phone (717) 3564-8721 • FAX (717) 354-2162  
**1-800-342-0905**  
[www.preseeder.com](http://www.preseeder.com)

# Slope-Tach Adapter

## List Of Parts Illustrations

Figure 1. Installation .....	2
Figure 2. Slope-Tach Assembly .....	4
Figure 3. Hydraulics and Related Parts.....	6

# Slope-Tach Adapter



## Safety, Installation, Operation & Maintenance

New Holland, PA 17557  
Phone (717) 3564-8721 • FAX (717) 354-2162  
1-800-342-0905  
www.preseeder.com

### SAFETY

SAFETY is our first concern at ATI Corporation. Safety must also be first in the mind of the operator of the Slope-Tach adapter. Proper maintenance is necessary to complete the safety cycle.

Observe all safety rules, including:

- Operate at a safe distance from bystanders.
- Never perform maintenance or service work such as lubricating, inspecting, clearing debris, etc., while the engine is running. Shut off the engine and remove the key before performing these functions.
- Engage skid steer loader parking brake before dismounting to engage or disengage latch pin handles, or connect or disconnect any auxiliary hydraulics.
- Ensure that the adapter and any equipment attached to the adapter are securely seated in the saddle of the attachment plate.
- The latch pins must be fully engaged, with the handles pushed over-center, fully in the latched position.

### OVERVIEW

The Slope-Tach adapter provides a tilt function for devices attached to a skid steer loader arms. This tilt function is especially helpful when grading along slopes. Normally, the angle of the cutting edge of a bucket or grading box matches the slope of the skid steer loader tires. This limits the direction of travel when creating a slope. The Slope-Tach adapter allows an attachment to be tilted side to side without regard for the position of the loader's tire orientation.

The Slope-Tach adapter is essentially two universal mounting plates that pivot in relation to each other. One mounting plate attaches to the loader arms and the second allows attachment of the device. Between the two mounting plates is a pivot pin and two cylinders.

The Slope-Tach adapter is for general use with virtually any device that can be mounted to the skid steer loader adapter plate, such as buckets, milling machines, or grading boxes. The tilt function is controlled by the skid steer loader auxiliary hydraulics.

*NOTE: If the attachment requires hydraulic power and the skid steer loader has only one set of auxiliary connections, provision must be made for a flow divider in the auxiliary hydraulics circuit.*

*NOTE: For mounting ATI's Para-Level Laser Grading Box, a hydraulic valve package is available that incorporates the tilt function of the Slope-Tach adapter into the Para-Level Laser Grading Box's hydraulic system. Contact your local dealer or ATI Corporation.*

### INSTALLATION

#### Mounting the Slope-Tach on the Skid Steer Loader

1. Disconnect any installed attachment from the skid steer loader in a clear, level location. Leave the latch handles on the skid steer adapter plate "open" to accept the Slope-Tach adapter.
2. Drive to the Slope-Tach adapter (1). Extend the bucket cylinders fully and position the skid steer loader adapter plate (2) in the mounting saddle (3). (Refer to Figure 1.)

*NOTE: It may be necessary to raise the top of the Slope-Tach adapter to allow the adapter plate to enter the saddle.*

3. With the Slope-Tach adapter (1) seated on the skid steer loader adapter plate (2), roll the bucket cylinders back to allow the bottom of the adapter plate to swing in against the lower part of the Slope-Tach adapter.

## Safety, Installation, Operation & Maintenance

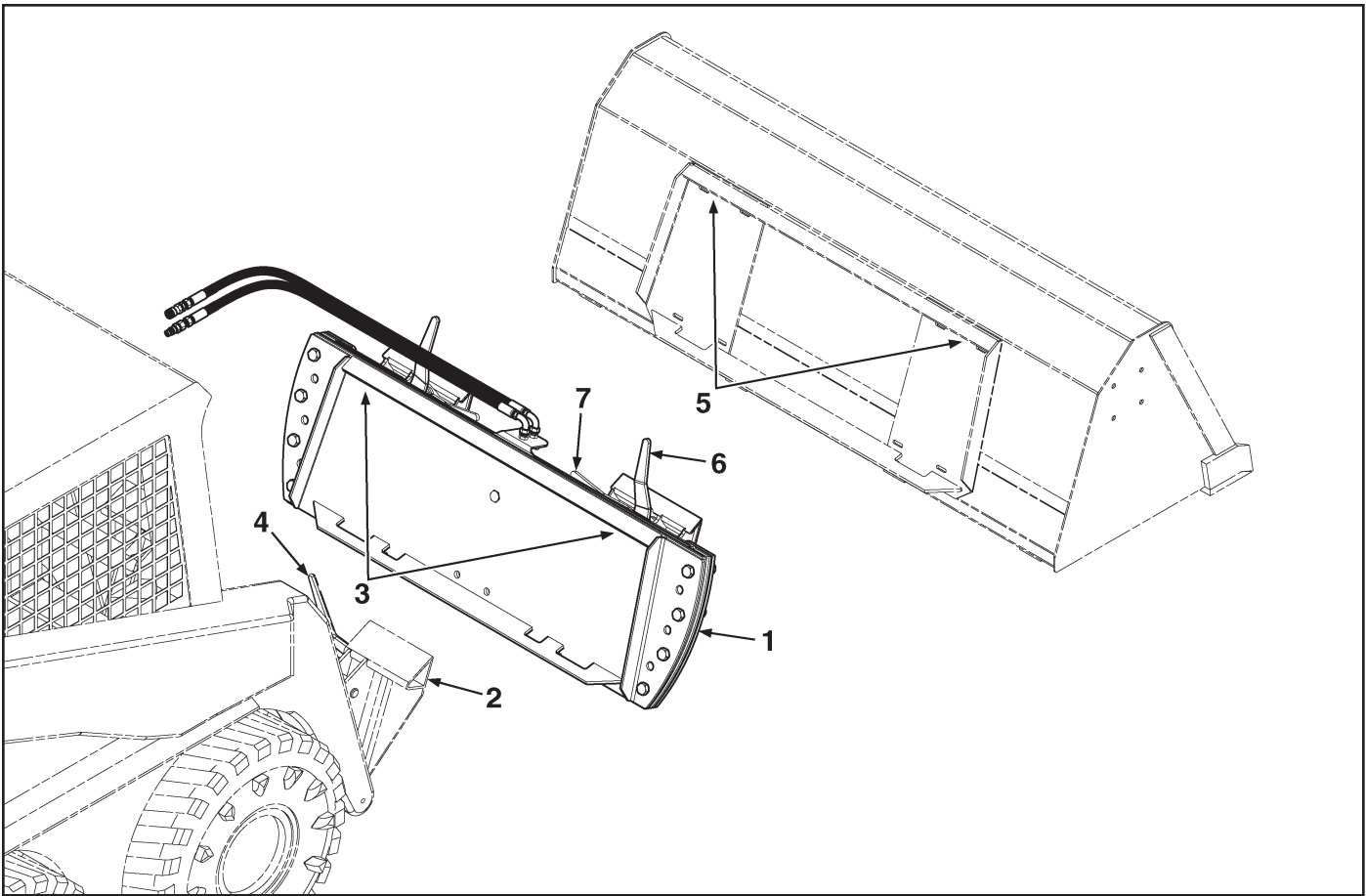

**Figure 1. Installation**

### **⚠ WARNING**

**The latch handles must go over-center to lock the attachment to the skid steer loader.**

4. Set the skid steer loader parking brake and secure the Slope-Tach adapter to the attachment plate using the latch handles (4) on the skid steer loader adapter plate.

#### Skid Steer Loader Hydraulic Connections

*NOTE: Most attachments will use the auxiliary hydraulics function of the skid steer loader to control the tilt function. For attachments which already take advantage of the auxiliary hydraulics port on the skid steer loader, provision needs to be made for an*

*additional hydraulic line either through an additional auxiliary port on the skid steer loader or by adding a flow divider valve on the attachment. This connection is left to the discretion of the installer.*

5. Located on the center of the Slope-Tach adapter are two #6JIC male fittings for attaching hoses to the skid steer quick couplers. Attach appropriate length hoses fitted with quick couplers to the fittings.
6. Attach the quick couplers to the skid steer loader auxiliary hydraulics.
7. Secure hoses along the Slope-Tach frame and loader arms to prevent pinching and rubbing.

# Slope-Tach Adapter

## Safety, Installation, Operation & Maintenance



New Holland, PA 17557  
Phone (717) 3564-8721 • FAX (717) 354-2162  
1-800-342-0905  
www.preseeder.com

### Installing Attachments on the Slope-Tach Adapter

1. Drive the skid steer loader to the desired attachment.
2. Ensure that the latch pins on the attachment side of the Slope-Tach adapter (6) are raised (open) to accept the attachment.
3. Using the skid steer hydraulics, extend the loader bucket cylinders and position the top front of the Slope-Tach adapter in the attachment saddle (5).
4. With the Slope-Tach adapter (1) seated in the attachment mounting plate (5), raise the loader arms as the bucket cylinders are rolled back, scooping up the attachment and allowing the attachment to swing in against the lower part of the Slope-Tach adapter.

### **WARNING**

**The latch pin handles must go over-center to lock the attachment to the Slope-Tach adapter.**

5. After the attachment is securely seated against the front of the Slope-Tach adapter, set the skid steer loader parking brake and push the latch pin handles down to the over-center latched position (7).

### **MAINTENANCE**

Attachments are secured to the quick attach with an over center latching pin system. It is important that these parts are kept clean, lubricated, and free of debris. Keep the latching pin free from dirt and debris. Lubricate the latching pin and the latching pin handle weekly with grease. Grease the pins and handles with the latching pin handles down in the latched position.

Keep latching pin handles tight. If handles become loose, tighten the hex nut slightly to snug up handles.

Clean the saddle at the top of the attachment plate, and the latching pin holes of any dirt and debris before mounting an attachment to the quick attach.

# Slope-Tach Adapter

## Figure 2. Slope-Tach Assembly

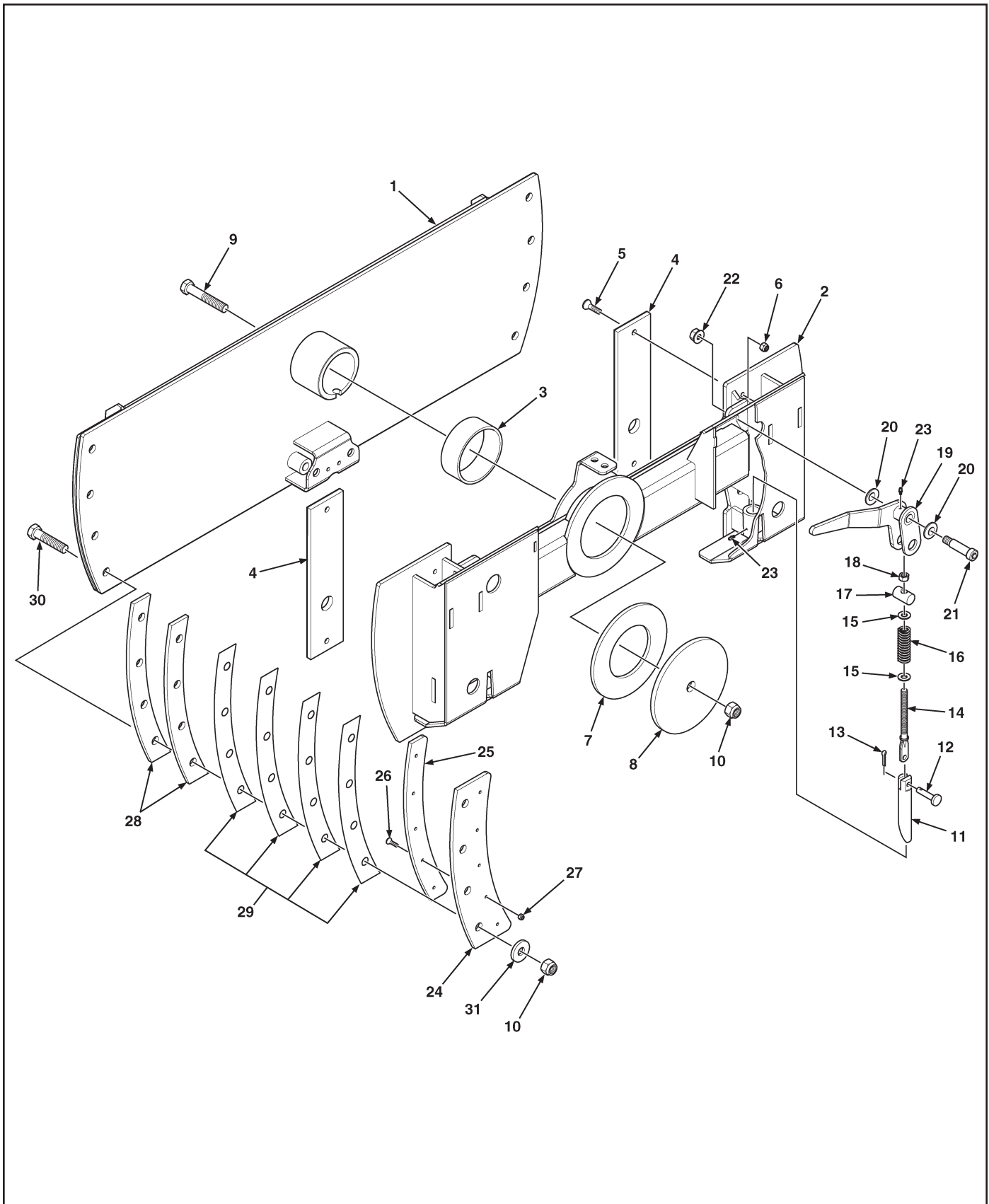

# Slope-Tach Adapter



**Figure 2. Slope-Tach Assembly**

New Holland, PA 17557  
 Phone (717) 3564-8721 • FAX (717) 354-2162  
**1-800-342-0905**  
 www.preseeder.com

Item	Part No.	Qty	Description
1	100-192-200	1	Frame Weldment, Attachment
2	100-192-100	1	Frame Weldment, Tilt, Includes Item 3
3	000-176-260	1	Bushing, Nylon, 5-1/2" OD x 5" ID x 2" Long
4	100-094-007	2	Pad, Main Slide
5	LP	4	Screw, Flat Head, Slot, 3/8"-16UNC x 1-1/4" Long
6	LP	4	Nut, Hex, Nylon Lock, 3/8"-16UNC
7	100-192-008	1	Disk, Slide
8	100-192-001	1	Cap Weldment, Pivot
9	LP	1	Bolt, Hex Head, 3/4"-16UNF x 5" Long
10	000-158-182	9	Nut, Hex, Nylon Lock, 3/4"-16UNF
11	000-161-043	2	Pin, Latch, Round
12	000-161-015	2	Pin, Clevis, 3/8" Dia. x 1-1/4" Long
13	LP	2	Pin, Cotter, 5/32" Dia. x 1" Long
14	000-161-061	2	Pin, Spring (Connecting Rod)
15	000-155-056	4	Washer, Flat, 1/2" SAE
16	000-161-013	2	Spring, Compression
17	000-161-044	2	Pin, Pivot, 1" Dia. x 1-3/4" Long
18	LP	2	Nut, Hex, Nylon Lock, 1/2"-13UNC
19	100-094-350	1	Handle, Latch, Pin, Left (Shown)
	100-094-300	1	Handle, Latch, Pin, Right (Not Shown)
20	000-161-014	4	Spring, Belleville Disc
21	000-150-326	2	Bolt, Socket Head, 3/4" Dia. x 2-1/4" Shoulder, 5/8"-11UNC
22	000-158-141	2	Nut, Hex, Flange, 5/8"-11UNC
23	000-166-002	AR	Fitting, Lube, 3/16" Drive
24	100-094-001	2	Plate, Slide Retainer
25	100-094-005	1	Pad, Slide, Right (Shown)
	100-094-004	1	Pad, Slide, Left (Not Shown)
26	LP	10	Screw, Flat Head, Socket, 1/4"-20UNC x 1" Long
27	LP	10	Nut, Hex, Nylon Lock, 1/4"-20UNC
28	100-094-002	6	Shim, Retainer, 3/8"
29	100-094-003	AR	Shim, Retainer, 1/16"
30	LP	8	Bolt, Hex Head, 3/4"-16UNF x 3-1/2" Long
31	000-155-094	8	Washer, Slide Support

**AR - As Required    NSS - Not Serviced Separately    ASN - After Serial No.    BSN - Before Serial No.    LP - Local Purchase**



New Holland, PA 17557  
Phone (717) 3564-8721 • FAX (717) 354-2162  
1-800-342-0905  
www.preseeder.com

# Slope-Tach Adapter

## Figure 3. Hydraulics and Related Parts

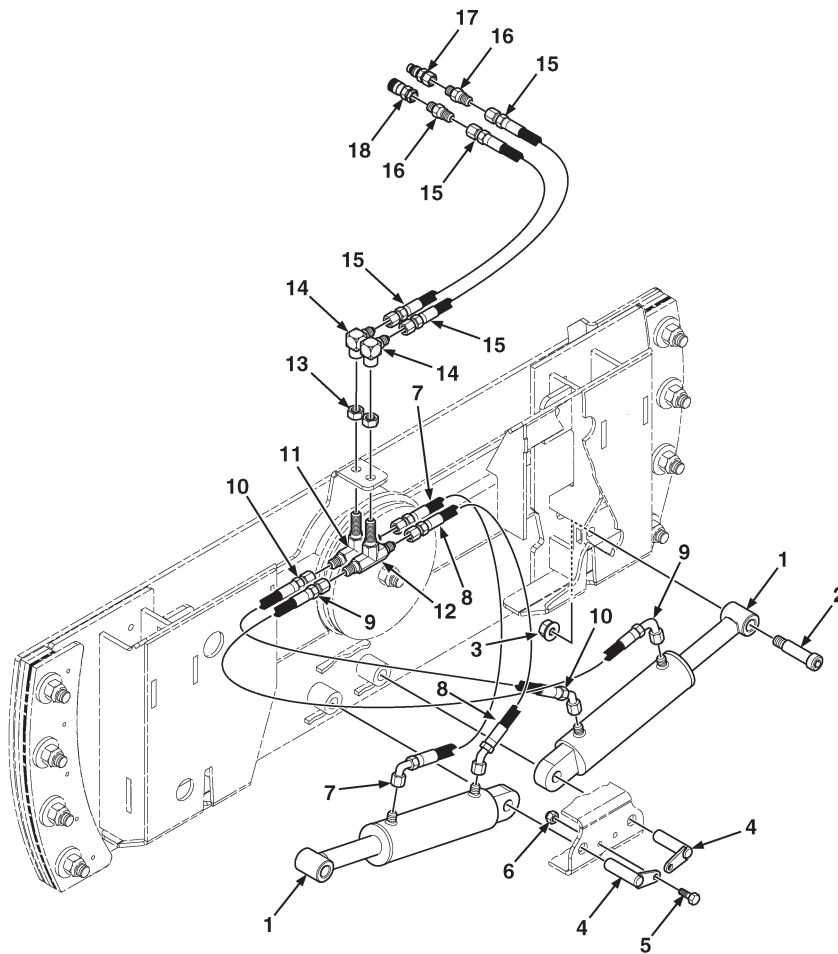

# Slope-Tach Adapter



New Holland, PA 17557

Phone (717) 3564-8721 • FAX (717) 354-2162

1-800-342-0905

www.preseeder.com

**Figure 3. Hydraulics and Related Parts**

Item	Part No.	Qty	Description
1	000-166-465	2	Cylinder Assembly, 2-1/4" Bore x 6" Stroke
2	000-150-326	2	Bolt, Socket Head, 3/4" Dia. x 2-1/4" Shoulder, 5/8"-11UNC
3	000-158-141	2	Nut, Hex, Flange, 5/8"-11UNC
4	000-161-027	2	Pin, Cylinder, 3/4" Dia. x 2-3/4" Long
5	LP	2	Bolt, Hex Head, 5/16"-18UNC x 1" Long
6	LP	2	Nut, Hex, Nylon Lock, 5/16"-18UNC
7	000-166-422	1	Hose Assembly, 3/8" Dia. x 6FJX x 6FJX90 x 37" Long, 3000 PSI
8	000-166-421	1	Hose Assembly, 3/8" Dia. x 6FJX x 6FJX45 x 30" Long, 3000 PSI
9	000-166-422	1	Hose Assembly, 3/8" Dia. x 6FJX x 6FJX90 x 37" Long, 3000 PSI
10	000-166-421	1	Hose Assembly, 3/8" Dia. x 6FJX x 6FJX45 x 30" Long, 3000 PSI
11	000-166-102	1	Fitting, Tee, Bulkhead, 6MJ x 6MJ x 6BH, Includes Item 13
12	000-166-486	1	Fitting, Tee, Bulkhead, 6MJ x 6MJ x 6BH, With .094 Orifice, Includes Item 13
13	NSS	2	Nut, Hex, Lock
14	000-166-110	2	Elbow, 90°, 6MJ x 6FJX
15	000-166-116	2	Hose Assembly, 3/8" Dia. x 65" Long x 6FJX x 8MJ, 4,000 PSI
16	000-166-108	2	Adapter, Straight, 12MB x 8FB
17	000-166-068	1	Coupler, Quick Disconnect, Flat Face, Male
18	000-166-069	1	Coupler, Quick Disconnect, Flat Face, Female

BH-Bulkhead
MP-Male Pipe
FP-Female Pipe
FPX-Female Pipe Swivel
MB-Male O-Ring Boss
FB-Female O-Ring Boss
MJ-Male JIC
FJ-Female JIC
FJX-Female JIC Swivel

<b>AR - As Required</b>	<b>NSS - Not Serviced Separately</b>	<b>ASN - After Serial No.</b>	<b>BSN - Before Serial No.</b>	<b>LP - Local Purchase</b>
-------------------------	--------------------------------------	-------------------------------	--------------------------------	----------------------------